

Oberer Drehpunkt mit integriertem Obentürschließer
 Top pivot point with integrated door closer
 Point de rotation supérieur avec un ferme-porte intégré

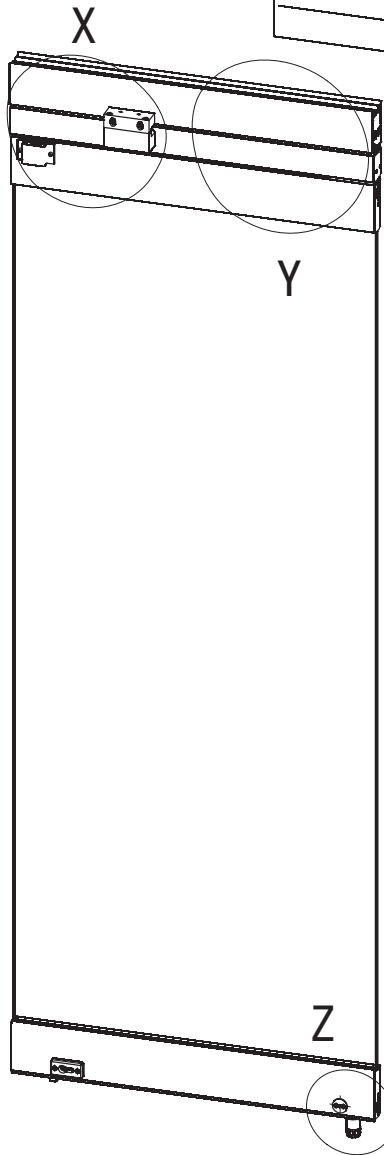

Frontfeststeller
 Floor lock
 Verrou bas

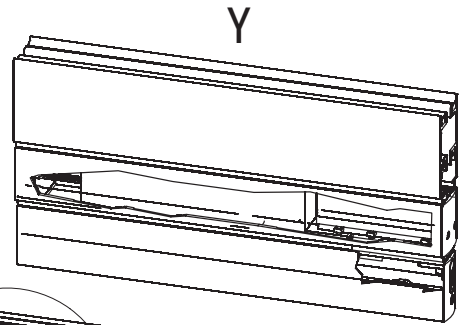
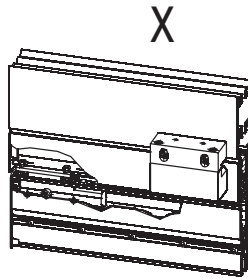
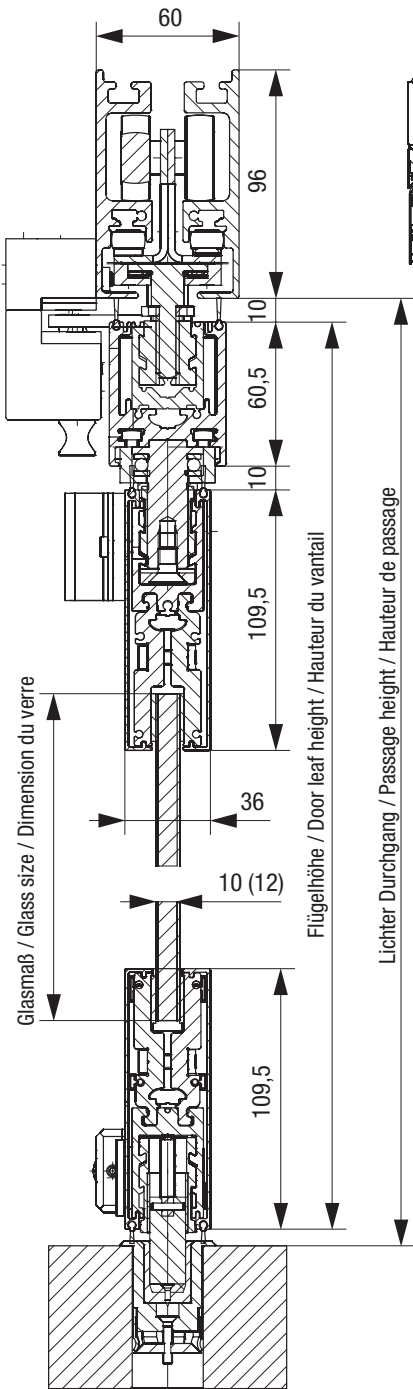
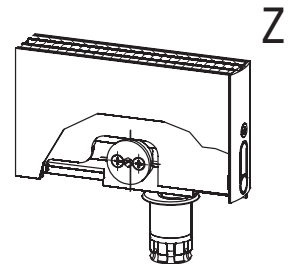

- Maximale Flügelbreite
 Maximum panel width
 Largeur maximale de vantail ≤ 1250 mm
- Maximale Flügelhöhe
 Maximum panel height
 Hauteur maximale de vantail ≤ 3000 mm
- Maximales Flügelgewicht
 Maximum panel weight
 Poids maximal de vantail ≤ 150 kg

Datum		Benennung / Description / Désignation
Bearb.		shop Master GSW-M Drehschiebe-/Pendelflügel Side hung sliding panel / Swing panel Vantail coulissant et battant / Vantail va-et-vient
Gepf.		
Norm		Zeichnung-Nr. / Drawing no. / Plan N°
 ATS GmbH Stahlstraße 8 33378 Rheda-Wiedenbrück <small>ATS ist ein Unternehmen der Gretsch-Unitas Gruppe</small>		016_612
		<small>Änderungen vorbehalten / Subject to alteration / Sous réserve de modifications</small>